



Large character inkjet

Videojet 2380 high-resolution inkjet printer

Discover a mess-free way to print on cases and cartons



Maximise your production uptime

The Videojet 2380 inkjet printer offers the complete solution for marking cases and cartons. Modular and easy to integrate, it delivers worry-free operation.

This large character marking system is designed for operation and maintenance by any user with minimal training or experience.

Patented micro-purge technology automatically performs routine printhead cleaning, helping to ensure consistent print quality with less mess or maintenance.

The Videojet 2380 delivers fast start-up and prints durable, high-resolution text, logos and bar codes, ready to meet the demands of the distribution chain.

Print-on-demand case coding

A print-on-demand case coding solution offers significant operational benefits:

- Use of variable production data, such as lot code and date of manufacture
- Streamlining of purchasing requirements and reduction of unique case inventory
- Reduced costs, required storage space and opportunity for waste
- Increased flexibility to quickly react to changes in content, as well as product demand
- Avoid production line downtime due to carton box shortages, minimising opportunity costs
- Pre-designed information helps to reduce operator typing errors



An **adaptable** marking solution

The Videojet 2380 printer is a versatile solution that adapts to your unique marking and coding requirements.



Key features:

Ability to use two printheads

The Videojet 2380 allows coding of up to 5.5-inch (140-mm) high print spaces, or coding on two sides of a box. Two printheads can be easily integrated, with no additional hardware needed, for a low-cost, future-proof solution.

Embedded protocols for connectivity and compatibility

The system offers USB, VideojetConnect™ and ZPL emulation.

Bar code scanner

The HMI easily integrates with a bar code scanner for rapid job selection and data entry.

Wi-Fi connectivity ready

Wi-Fi is embedded in the printer, for remote access and analytical capabilities.

Reliable case coding for distribution chain efficiency

The Videojet 2380 can handle complex prints, including bar codes, texts, logos and multilingual support.

In addition, case coding can help to:

- ensure traceability of product and packaging
- support manufacturer compliance
- automate factory and warehouse processes
- improve the visual appearance of cases and branding



A consistent marking solution

The Videojet 2380 delivers continuously reliable high-quality codes on corrugated cardboard and other porous materials.



Key features:

Self-cleaning printhead

The system can be programmed to clean the printhead at specific intervals without stopping the production line.

Air knife

This helps to clean the printhead nozzle plate, supporting long production runs.

Gyroscopic sensor

This monitors the printer mounting angle in real-time, helping to prevent ink leaks. It also detects and records external impact signals.



Technology that maintains consistent print quality

Videojet 2380 micro-purge technology outperforms other purging methods, cleaning the printhead nozzles and helping to prevent blockages.

- It is automatic – no need for plant personnel to initiate the process
- The short purge time can be coordinated to occur between prints
- Purged ink is returned to the print system, reducing running costs

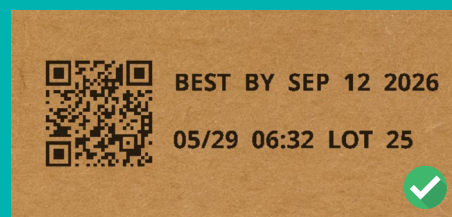

An **easy-to-use** marking solution

A touchscreen user interface offers onboard job editing and can be placed in an optimal position for the operator.



Key features:

SIMPLICiTY™ interface

An intuitive, easy-to-use HMI that offers code assurance and guides you every step of the way, greatly reducing printer interactions and potential user errors.

Take control

Manage up to two printheads with the same touchscreen.

Easy upgrade

Existing CLARiTY™ print jobs are 100% compatible with the Videojet 2380 and can be downloaded via USB.

Less mess, less maintenance

The Videojet 2380 has been designed to reduce and simplify maintenance.

A low-cost return line filter changes the associated ink-cup cleaning cycle from daily to monthly. This helps users avoid the clogs and mess often associated with missed cleaning intervals, minimising the risk of leaking ink.

Wiping the printhead surface is the only daily maintenance recommended.

A priming process eliminates the need for external equipment and makes it quick and easy to get the printer back online if it needs to be re-primed.



An expert marking solution

The Videojet 2380 is made of durable 304-grade stainless steel, ideal for secondary production environments.



Key features:

Ink recycle feature

Costs are reduced because ink used in printhead cleaning is reclaimed and reused by the printer.

Contrast adjuster

Allows the contrast density to be reduced, enabling more prints per ink canister.

Robust printhead

Optimal uptime delivered through proven print technology.

Durable and economical large character codes

Cases with large character text and bar codes are frequently exposed to a variety of environmental conditions.

Ink-based codes are ideal for adhesion to corrugate fibres and are more durable than wax-based coding options.

Users can print in less than a minute, and the cost of on-demand inkjet printing is a fraction of print-and-apply labelling solutions.

Videojet offers a wide selection of inks for use in the 2380.

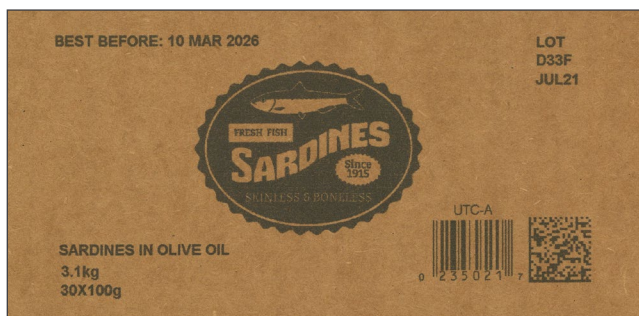



Videojet LifeCycle Advantage™

The Videojet 2380 leverages advanced analytics, remote connectivity and the largest service footprint in the industry to maintain our uptime commitment, improve operations over time and help you recover in minutes from unplanned interruptions.

Improve

- Leverage data across a fleet of connected printers to continually optimise printer performance
- Remote service data can be used to identify operational improvements and help you run your plant better



Maintain

- Get optional on-demand remote training at the touch of a button
- Service packages for periodic preventive maintenance help keep your printer in peak condition
- Configurable remote alerts notify customers of pending faults and possible issues to allow proactive resolution between production shifts

Recover

- Many repairs can be resolved with the assistance of the Videojet team of experts in minutes, and without waiting for on-site service
- Benefit from the largest global service organisation in the industry to support your on-site needs when necessary

Printer technology to help meet your sustainability objectives

Sustainability is our driving force. The Videojet printer portfolio delivers the agility to stay ahead of constantly evolving regulatory and sustainability requirements and the resulting supply chain needs for waste reduction, recycling and optimisation.

Printers designed to reduce waste

Automated micro-purge technology helps to reduce downtime due to printhead blockages, while our patented ink recycling process virtually eliminates waste ink.

Case coding that eliminates labels

By printing durable, high-resolution bar codes, text and logos directly on cases and shipping cartons, our products help eliminate the use of paper, silicone and adhesives in labels.



Videojet® 2380

Large Character Inkjet

Print Speed

Bar code printing – 0.6 to 66mpm (2.0 to 216ft/min.)

Alphanumeric text – up to 132mpm (433ft/min.)

Speeds are density dependent

Print Distance

0.5mm to 4.0mm max. (0.02 - 0.15")

Print Area (per printhead)

70mm (H) x 2000mm (L) (2.8" x 78"), 180 dpi

Bar Codes

UPC A&E; EAN 8 & 13; Code 128 A, B & C; UCC/EAN 128; Code 39; Interleaved 2 of 5; RSS/GS1 Databar (including 2D composite codes); DataMatrix; QR codes

User Interface

8" high-response TFT-LCD touch screen

WYSIWYG touch to edit message editing

On-board diagnostics

Graphics, Images and Logos

Can be created via optional CLARISOFT™ software

Printing Capabilities

Full downloadable font support using TrueType® fonts (including multiple languages and Unicode support); fixed, variable and merged text fields; flexible date/time formats; flexible shift code formats; auto best before date calculations and concession management; calendar rules; auto incrementing decrementing text, counters and bar codes; multiple graphic formats supported (up to maximum print area); link fields to databases; scalable text and text blocks

Languages

English, Arabic, Bulgarian, Chinese (Mandarin), Czech, Danish, Dutch, Finnish, French, German, Greek, Hungarian, Italian, Japanese, Korean, Norwegian, Polish, Portuguese, Russian, Spanish, Swedish, Thai, Turkish and Vietnamese

On-Board Memory

8 GB memory

Inputs / Outputs

1 product detect input, 1 DB15 interface integrated shaft encoder input, job select inputs, 24VDC output, 3 configurable inputs and outputs for driving relay control or beacon
1 DB9 interface for sharing product detect and encoder signal between printers
1 USB 2.0 host

Supported Field Types

Fixed, variable (user entered), merged, database, counters, date, offsets, time, paragraph (Text Blocks)

Basic shape drawing (circles, rectangles etc.)

External Communications

Binary and ASCII comms protocols

Host PC mode (Remote Database) using CLARINET™

Zebra (ZPL) protocol

USB connectivity for job download and software update

Connectivity Options

RS232, dual Ethernet and Wi-Fi

Operation Modes

Single printhead in standard mode, two printheads in leader/follower mode

Network Control Software

CLARINET™ network management software

Ink/Ink System

Non-pressurized, screw-in canister; 175ml or 365ml

Colors available: black, blue, green, orange, purple, red, yellow

Power Supply

100V-240VAC, 50/60HZ, 50W

Air Supply

6 Bar, 90psi, dry, uncontaminated

Operating Temperature

10°-35° C (50°-95° F)

Weight

Unboxed: 3.75kg (8.3lbs); Boxed: 7.4kg (16.3lbs) (single head)

Options

SIMPLiTY Workflow Modules

Wide range of accessories



Dimensions

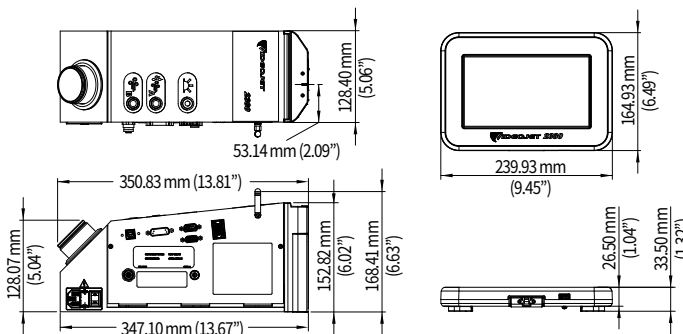

Call us free on **0800 500 3023**

Email uksales@videojet.com

or visit www.videojet.co.uk

Videojet Technologies Ltd.

4 & 5 Ermine Centre, Huntingdon, Cambridgeshire PE29 6XX / UK

Call us free on **+353 1 450 2833**

Email irelandsales@videojet.com

or visit www.videojet.ie

Videojet Ireland

C2, South City Business Park, Tallaght, Dublin 24 / Ireland

© 2024 Videojet Technologies Inc. — All rights reserved.

Videojet Technologies Inc.'s policy is one of continued product improvement. We reserve the right to alter design and/or specifications without notice.

Part No. SL000729

br-2380-en-0324

