

PART No.

SHT 1
OF 1

REV	INIT	DATE	ECO REVISION
01			INITIAL DRAWING

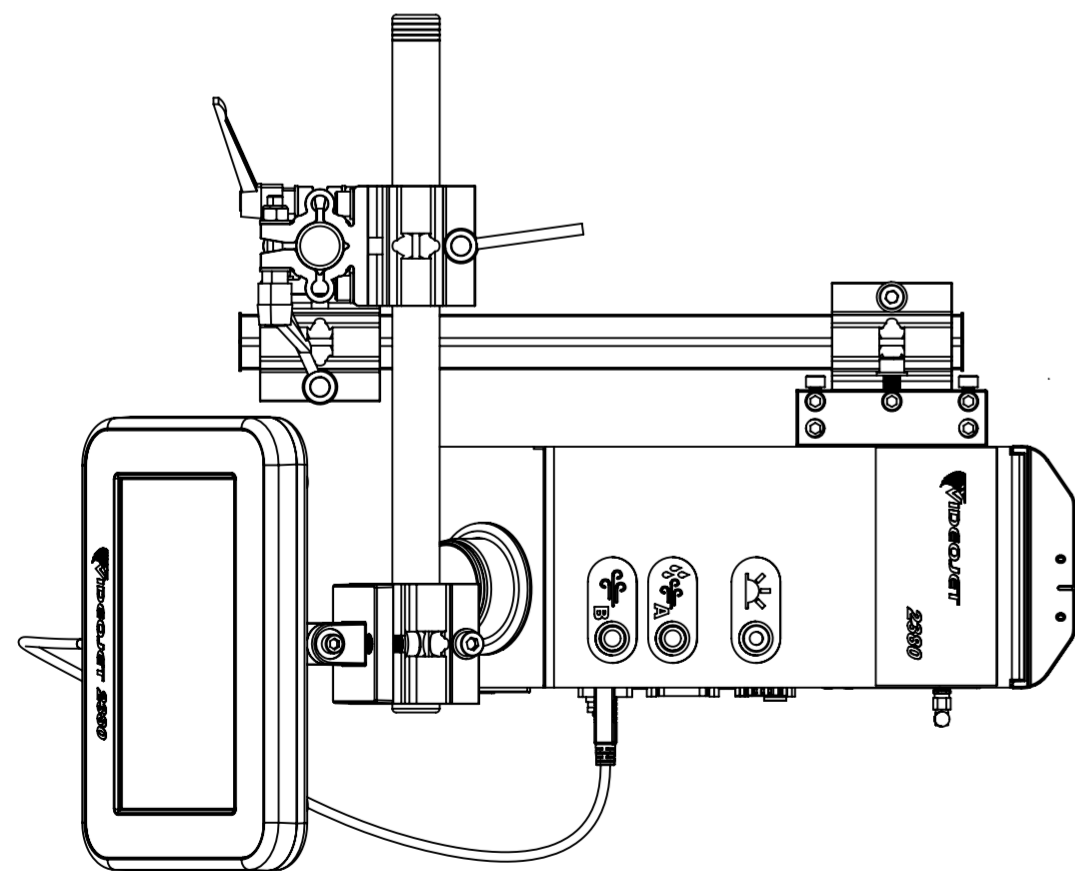
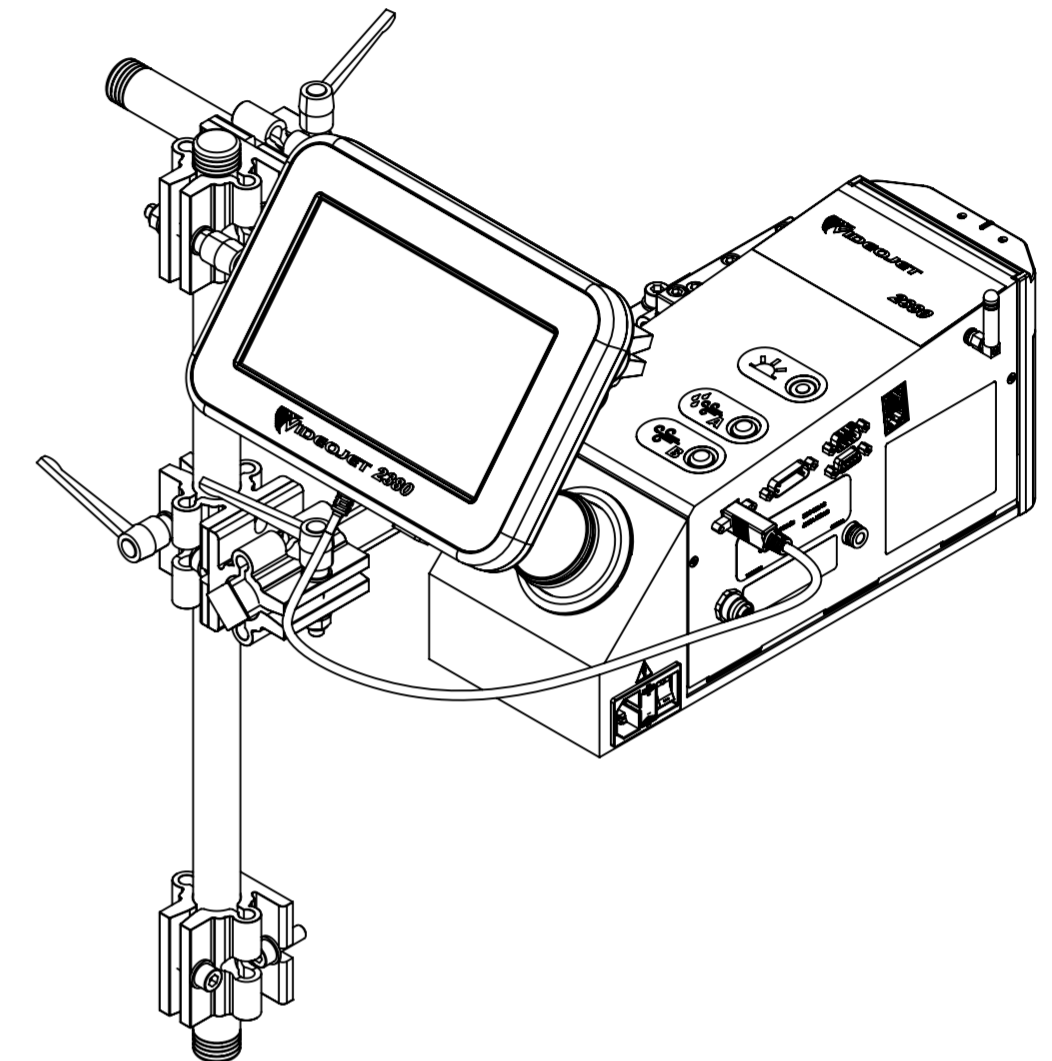
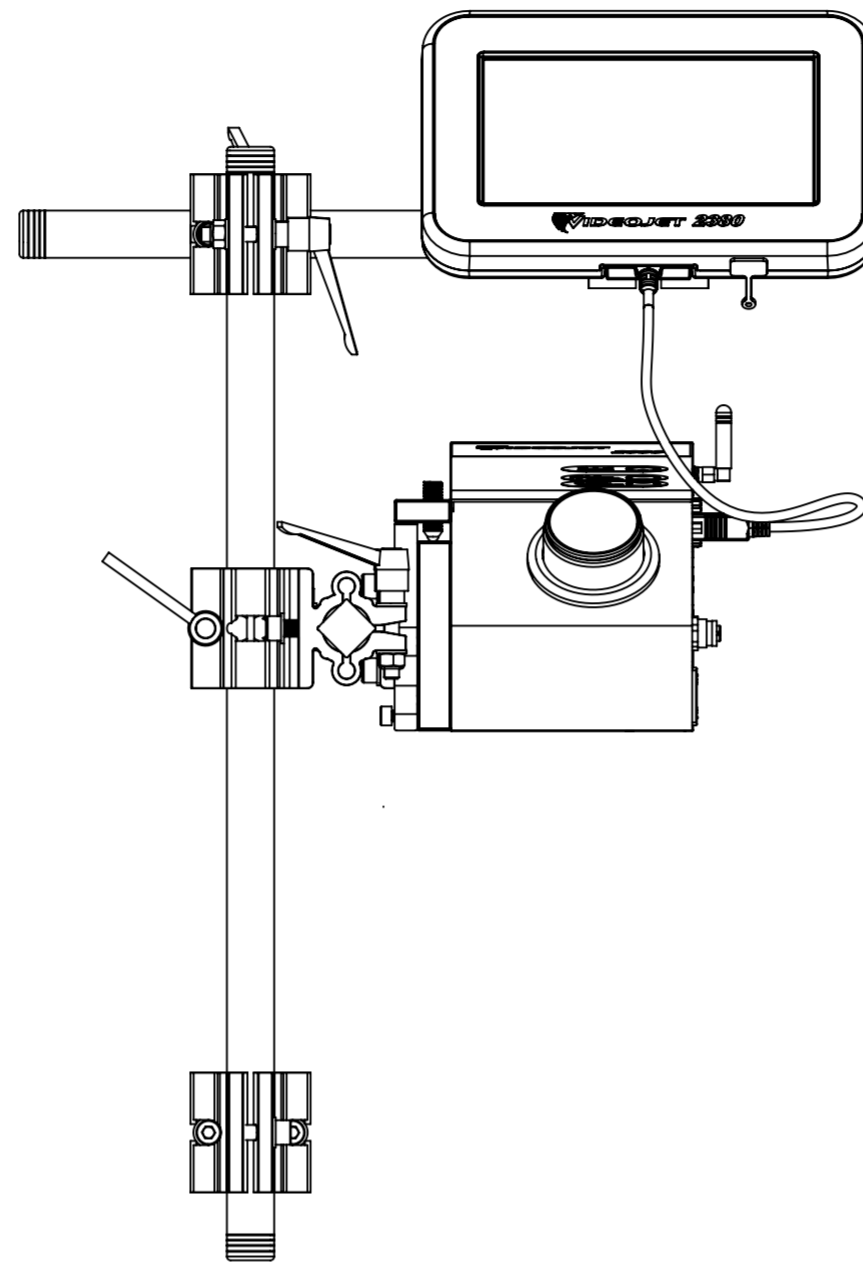
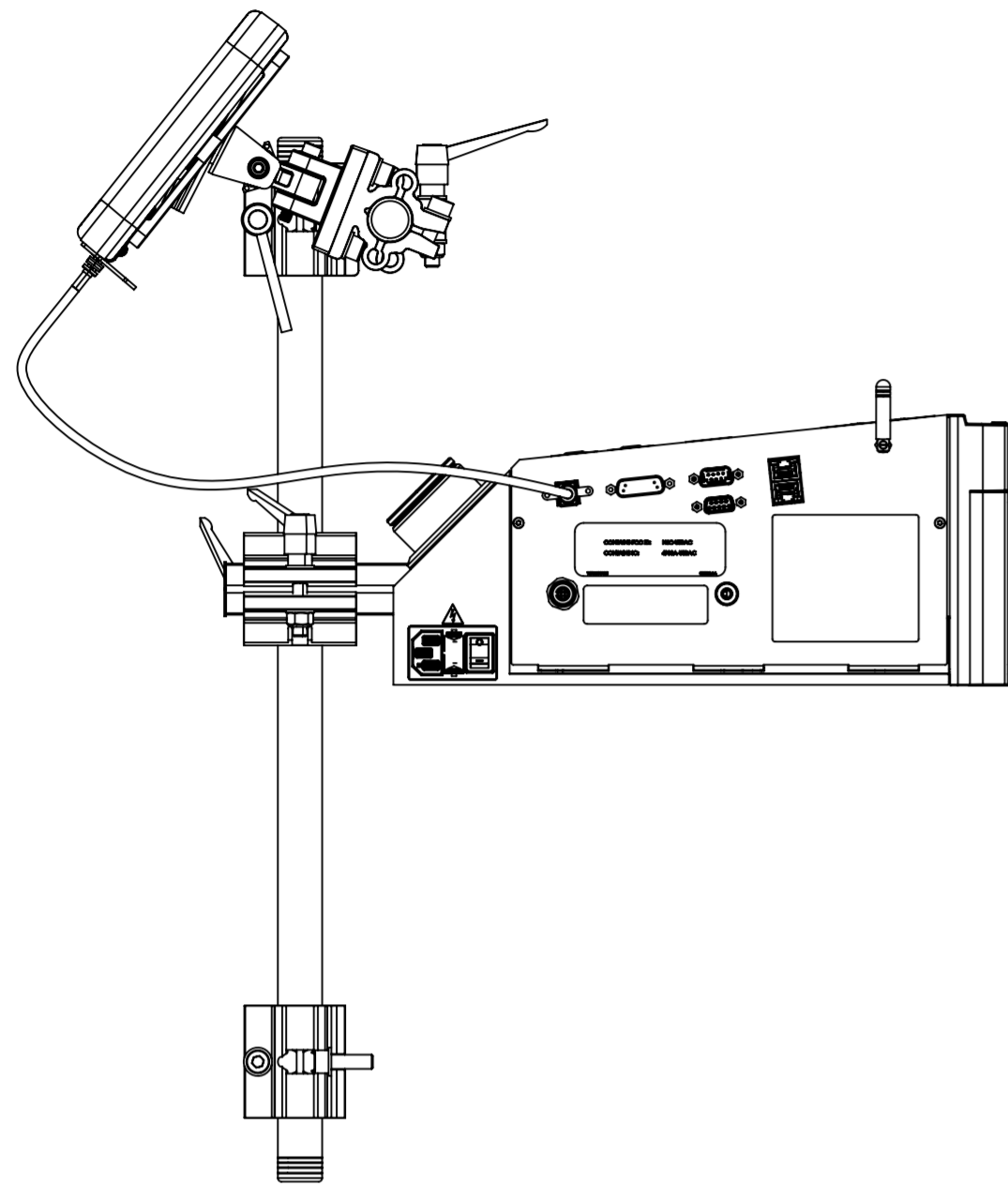

DRAFT

COMPLIANCE TO ALL CONTENTS IN VIDEOJET DOCUMENT #W00-PM-5504 TO BE VERIFIED

DIMENSIONS IN MILLIMETRES
DO NOT SCALE - IF IN DOUBT ASK

SCALE
1:4 **A2**

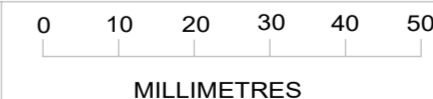

THIRD ANGLE PROJECTION

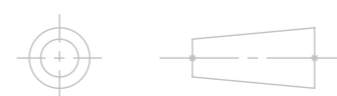

SHARP EDGES, BURRS ETC. TO BE REMOVED 0.3mm x 45° CHAMFER UNLESS OTHERWISE STATED.

© VIDEOJET TECHNOLOGIES INC

This drawing embodies confidential information which is the property of Videojet to whom the copyright in this drawing belongs. This drawing may not be copied or reproduced in whole or in part nor may it be used for any purpose other than that for which it was made available except with the prior specific written consent of Videojet. The provision of this drawing does not grant any rights under any Industrial Property rights of Videojet nor of any third party.

TOLERANCES UNLESS OTHERWISE STATED
INTERNAL DIA'S TO H11.
ANGULAR ± 0.5°

ZERO DECIMAL PLACES ± 0.5
ONE DECIMAL PLACE ± 0.2
TWO DECIMAL PLACES ± 0.1
MACHINING 1.6
GENERAL FINISH

DRAWN Kevin Gao
DATE 11 Jan 2024
APPD.
DATE
REL.
DATE

MATERIAL
FINISH
TITLE
Single 2380 printer with UI on conveyor mounting bracketry

PART No.
REV
01